

(3 Hours)

[Total Marks: 80]

1. Question No. 1 is compulsory.
2. Attempt any three out of the remaining five questions.
3. Assume suitable data if necessary
4. Figures to right indicate full marks.

07/12/17
Nov-17

- Q.1 (a) Prove that $1.1! + 2.2! + 3.3! + \dots + n.n! = (n+1)! - 1$, where n is a positive integer. [5]
- (b) Let $A = \{a, b, c\}$. Show that $(P(A), \subseteq)$ is a poset and draw its Hasse diagram. [5]
- (c) Explain the terms : - (i) Lattice [5]
(ii) Poset
(iii) Normal Subgroup
(iv) Group
(v) Planar Graph
- (d) Comment whether the function f is one to one or onto. [5]
Consider function: $f: N \rightarrow N$ where N is set of natural numbers including zero.

$$f(j) = j^2 + 2$$

- Q.2 (a) Find the number of ways a person can distribute Rs. 601 as pocket money to his three sons, so that no son should receive more than the combined total of the other two. (Assume no fraction of a rupee is allowed.) [6]
- (b) Let $A = \{a_1, a_2, a_3, a_4, a_5\}$ and let R be a relation on A whose matrix is [6]

$$M_R = \begin{vmatrix} 1 & 0 & 0 & 1 & 0 \\ 0 & 1 & 0 & 0 & 0 \\ 0 & 0 & 0 & 1 & 1 \\ 1 & 0 & 0 & 0 & 0 \\ 0 & 1 & 0 & 0 & 1 \end{vmatrix}$$

Find M_R^* by Warshall's algorithm.

- (c) Find the complete solution of the recurrence relation: [4]
 $a_n + 2a_{n-1} = n+3$ for $n \geq 1$ and with $a_0 = 3$.

- (d) Let $f: \mathbb{R} \rightarrow \mathbb{R}$ defined as $f(x) = x^3$ and [4]
 $g: \mathbb{R} \rightarrow \mathbb{R}$ defined as $g(x) = 4x^2 + 1$
 Find out $g \circ f, f \circ g, f^2, g^2$

- Q.3 (a) Given that a student had prepared, the probability of passing a certain entrance exam is 0.99. Given that a student did not prepare, the probability of passing the entrance exam is 0.05. Assume that the probability of preparing is 0.7. The student fails in the exam. What is the probability that he or she did not prepare? [6]

- (b) Define equivalence relation with example. Let 'T' be a set of triangles in a plane and define R as the set $R = \{(a,b) \mid a, b \in T \text{ and } a \text{ is congruent to } b\}$ then show that R is an equivalence relation. [6]

- (c) Let $A=B=\mathbb{R}$, the set of real numbers [4]
 Let $f: A \rightarrow B$ be given by the formula $f(x) = 2x^3 - 1$ and Let $g: B \rightarrow A$ be given by

$$g(y) = \sqrt[3]{\frac{1}{2}y + \frac{1}{2}}$$

Show that f is a bijection between A and B and g is a bijection between B and A.

- (d) Let Z_n denote the set of integers $\{0, 1, 2, \dots, n-1\}$. Let \circ be binary operation on Z_n such that $a \circ b =$ the remainder of ab divided by n . [4]
 (i) Construct the table for the operation \circ for $n=4$.
 (ii) Show that (Z_n, \circ) is a semigroup for any n .

- Q.4 (a) (i) Among 50 students in a class, 26 got an A in the first examination and 21 got an A in the second examination. If 17 students did not get an A in either examination, how many students got an A in both examinations? [6]

(ii) If the number of students who got an A in the first examination is equal to that in the second examination, if the total number of students who got an A in exactly one examination is 40 and if 4 students did not get an A in either examination, then determine the number of students who got an A in the first examination only, who got an A in the second examination only, and who got an A in both the examination.

(b) Consider the (2,5) group encoding function

$e : B^2 \rightarrow B^5$ defined by

$$e(00) = 00000$$

$$e(01) = 01110$$

$$e(10) = 10101$$

$$e(11) = 11011$$

[6]

Decode the following words relative to a maximum likelihoods decoding function.

(i) 11110 (ii) 10011 (iii) 10100

(c) (i) Is every Eulerian graph a Hamiltonian?

(ii) Is every Hamiltonian graph a Eulerian?

Explain with the necessary graph.

[4]

(d) Given the parity check matrix

[4]

$$H = \begin{pmatrix} 1 & 1 & 0 & 1 & 0 & 0 \\ 0 & 1 & 1 & 0 & 1 & 0 \\ 1 & 0 & 1 & 0 & 0 & 1 \end{pmatrix}$$

Find the minimum distance of the code generated by H. How many errors it can detect and correct?

Q.5 (a) Explain Pigeonhole principle and Extended Pigeonhole principle. Show that in [6]

any room of people who have been doing some handshaking there will always be atleast two people who have shaken hands the same number of times.

(b) Determine whether the Poset with the following Hasse diagrams are lattices or [6]

not. Justify your answer.

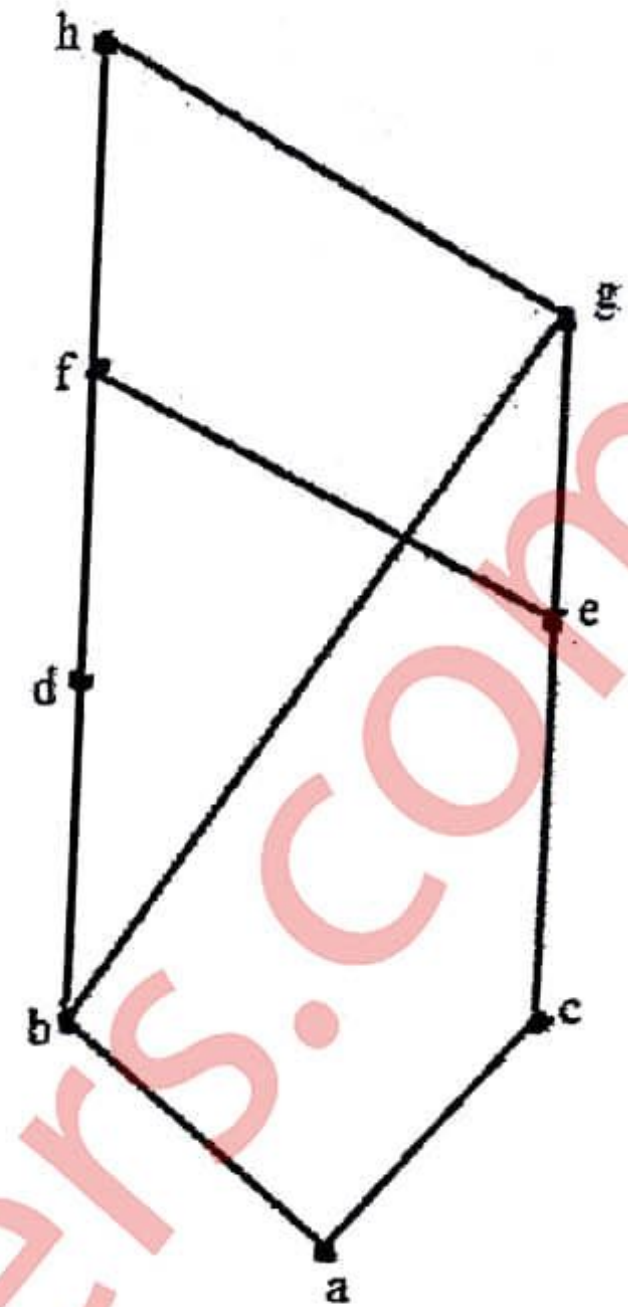
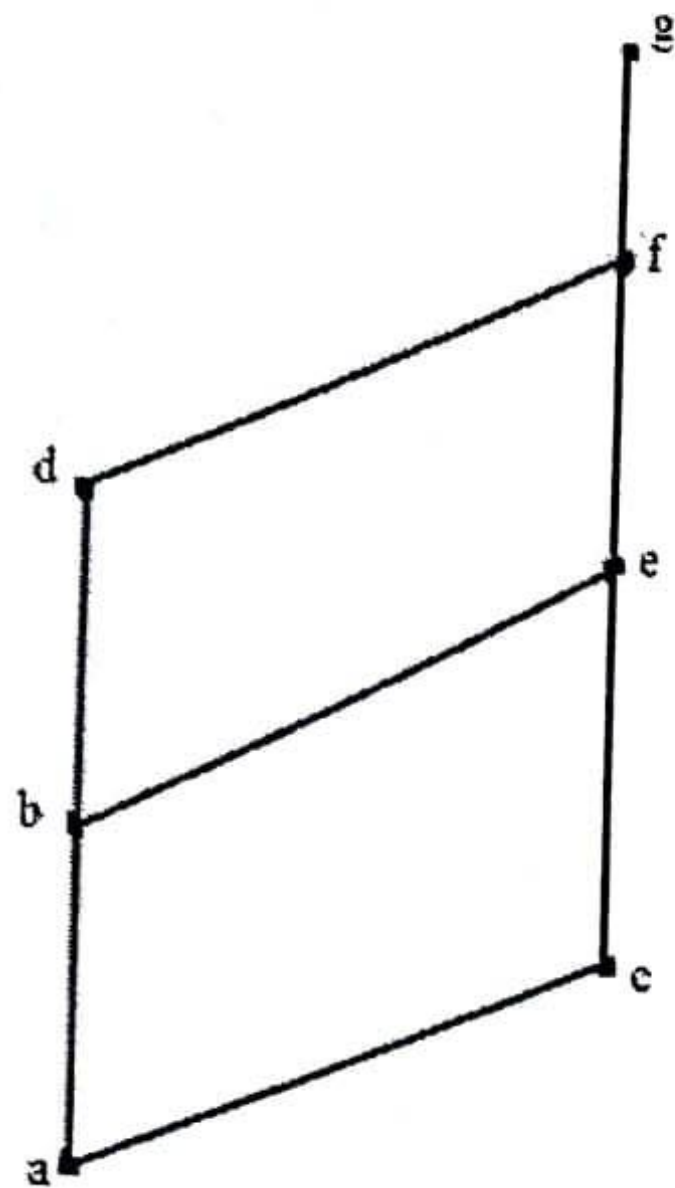

- (c) From the following digraphs, write the relation as a set of ordered pairs. Are the relations equivalence relations? [4]

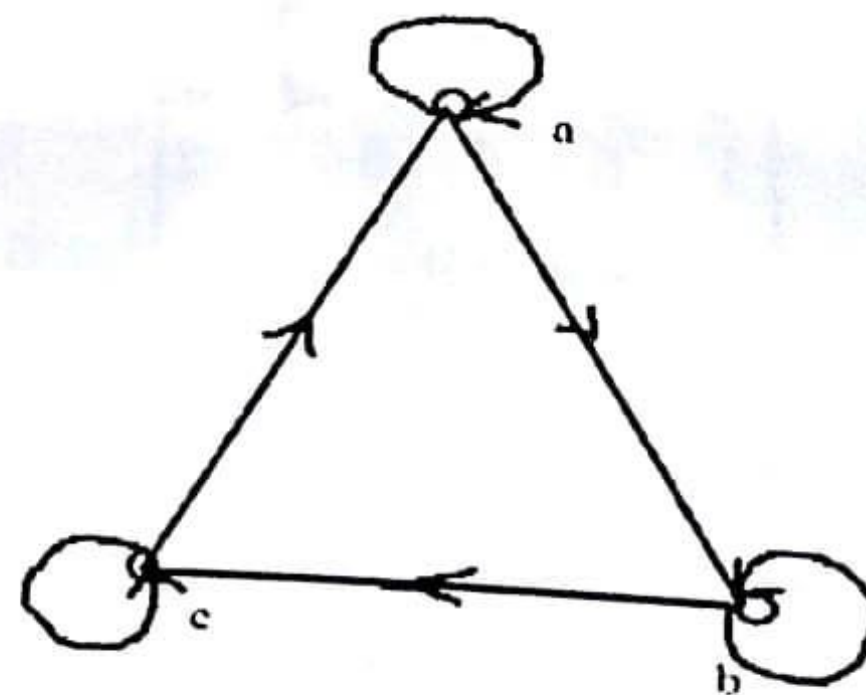
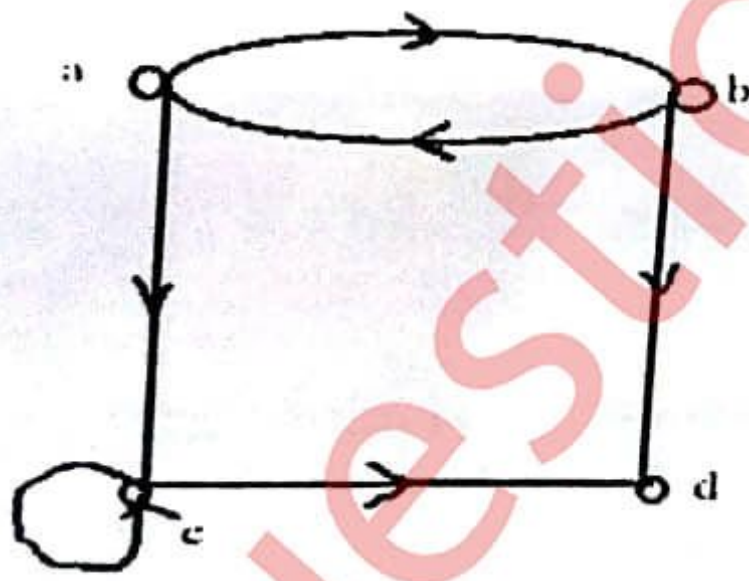

- (d) For the set $X = \{2, 3, 6, 12, 24, 36\}$, a relation \leq is defined as $x \leq y$ if x divides y . Draw the Hasse diagram for (X, \leq) . Answer the following: [4]
- (i) What are the maximal and minimal elements?
 - (ii) Give one example of chain & antichain.
 - (iii) Is the poset a lattice?

Q.6 (a) Prove that the set $\{1,2,3,4,5,6\}$ is group under multiplication modulo 7. [6]

(b) Given a generating function, find out corresponding sequence. [6]

(i) $\frac{1}{3-6x}$

(ii) $\frac{x}{1-5x+6x^2}$

(c) Determine whether following graphs are isomorphic or not. [4]

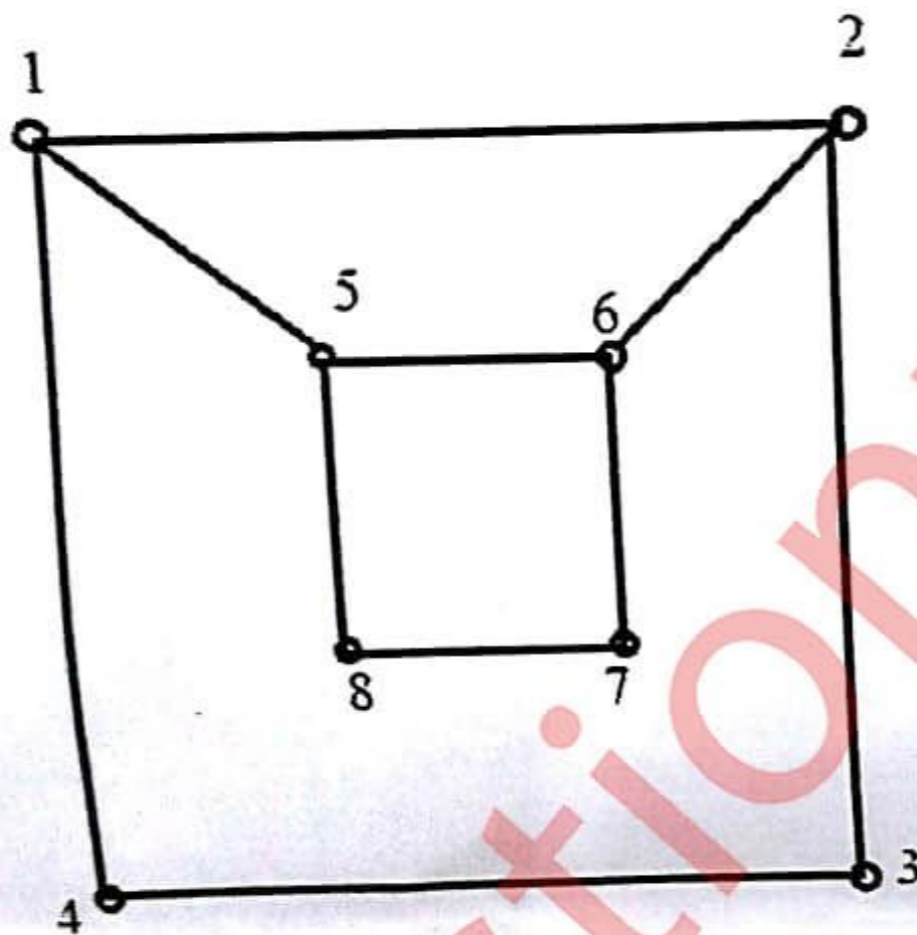

G_1

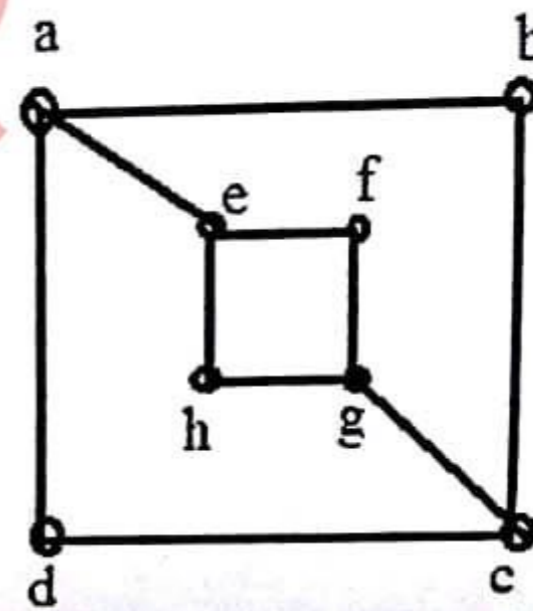

G_2

(d) Prove the following (use laws of set theory) [4]

$$A \times (X \cap Y) = (A \times X) \cap (A \times Y)$$